



<p>Client Dublin City Council</p> <p>Project Title Cromcastle Court and Old Coal Yard Part 8 Transport Assessment</p> <p>Drawing Title Proposed Transport and Road Layout Key Visibility Splays</p>	<p>Scale at A1 1:300</p> <p>Role Planning</p> <p>Suitability S2 - Suitable for Information</p> <p>Arup Job No 302494-00</p> <p>Name CROM-ARUP-ZZ-ZZ-SK-T-0001</p>	<p>Rev Date By Chkd Appd</p> <table border="1" style="width:100%; border-collapse: collapse;"> <tr> <td>P01</td> <td>19/03/25</td> <td>ES</td> <td>RB</td> <td>JF</td> </tr> </table> <p>ARUP Arup, 50 Ringsend Road Dublin, D04 T6X0 www.arup.ie Tel +353(0)1 233 4455 Fax +353(0)1 668 3169</p>	P01	19/03/25	ES	RB	JF
P01	19/03/25	ES	RB	JF			



A1
1
2
3
4
5
6
7
8
9
10

A B C D E F G H I J K L M N O P

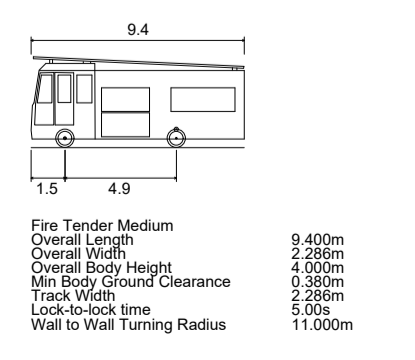

Rev	Date	By	Chkd	Appd
P01	19/03/25	ES	RB	JF

ARUP
 Arup, 50 Ringsend Road
 Dublin, D04 T6X0
 www.arup.ie
 Tel +353(0)1 233 4455 Fax +353(0)1 668 3169

Client
 Dublin City Council

Project Title
 Cromcastle Court and Old Coal Yard Part 8 Transport Assessment

Drawing Title
 Tracking Analysis Fire Tender

Scale at A1	1:250
Role	Planning
Suitability	S2 - Suitable for Information
Arup Job No	302494-00
Rev	P01
Name	CROM-ARUP-ZZ-ZZ-SK-T-0002

Do not scale CVAL50362430 © Tailte Eireann - Surveying

I:\projects\2025\03\20250324-004 - Inhomal-02 Drawing\A1-ZZ-ZZ-SK-T-0001.dwg
 19/03/25 14:00:00
 Tailte Eireann - Surveying

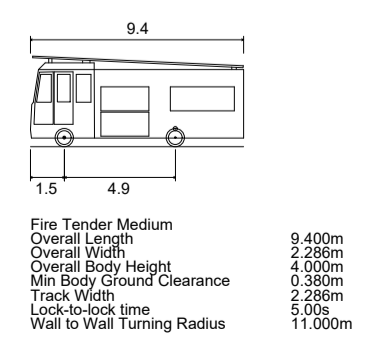
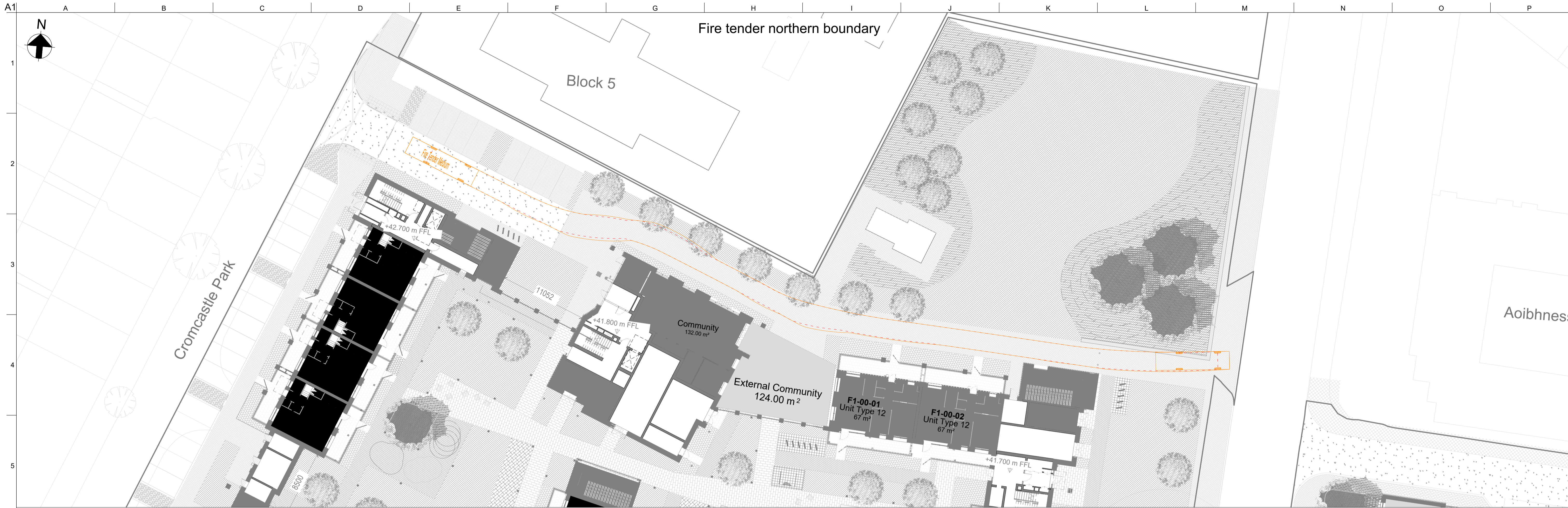

Rev	Date	By	Chkd	Appd
P01	19/03/25	ES	RB	JF

ARUP
 Arup, 50 Ringsend Road
 Dublin, D04 T6X0
 www.arup.ie
 Tel +353(0)1 233 4455 Fax +353(0)1 668 3169

Client
 Dublin City Council

Project Title
 Cromcastle Court
 and Old Coal Yard
 Part 8 Transport Assessment

Drawing Title
 Tracking Analysis
 Fire Tender Along Northern Boundary

Scale at A1	1:250
Role	Planning
Suitability	S2 - Suitable for Information
Arup Job No	302494-00
Rev	P01
Name	CROM-ARUP-ZZ-ZZ-SK-T-0003



1
2
3
4
5
6
7
8
9
10

A B C D E F G H I J K L M N O P

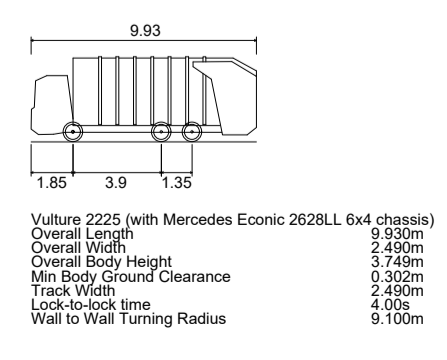
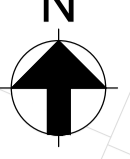

Rev	Date	By	Chkd	Appd
P01	19/03/25	ES	RB	JF

ARUP

Arup, 50 Ringsend Road
Dublin, D04 T6X0
www.arup.ie
Tel +353(0)1 233 4455 Fax +353(0)1 668 3169

Client
Dublin City Council

Project Title
Cromcastle Court
and Old Coal Yard
Part 8 Transport Assessment

Drawing Title
Tracking Analysis
Refuse Vehicle

Scale at A1 1:250

Role	Planning
Suitability	S2 - Suitable for Information
Arup Job No	302494-00
Rev	P01
Name	CROM-ARUP-ZZ-ZZ-SK-T-0004